

# STAGE KING 220V-440V 3PHASE D8 PLUS

The STAGE KING hoist series is the perfect choice for ultra-small spaces, thanks to its compact structure, small size, and lightweight design. Its design facilitates easy handling and operation in confined spaces. With an IP66 protection grade, the STAGE KING can operate efficiently even in rainy conditions. The hook is capable of 360-degree rotation and features an anti-decoupling design for enhanced safety. The G100 chain, certified to EN 818-7 standards, boasts an impressive 8 times safety factor. The integrated clutch on the rotor shaft uses a dry clutch friction plate, ensuring it does not slip even after wear, thus maintaining optimal safety. The electric magnetic braking system is maintenance-free and locks the brake immediately after a power failure. The helical gear transmission, with gear grade 6, ensures quiet operation with noise levels at 60 dB. The lower hook lifting ring is designed for safer use with a shackle. A high-strength special nylon chain guide guarantees smooth chain operation. The cast aluminum integrated shell, combined with heat treatment, makes the body more robust while reducing its weight.

The clutch is on the transfer shaft of the motor.

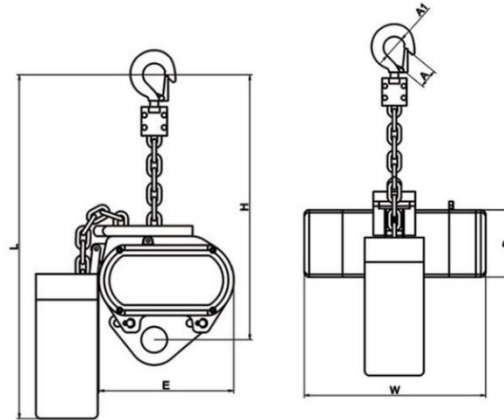

General specifications:	
SWL acc. DGUV V54 (D8+):	250kg / 800kg
Direct Control:	220- 440V 3ph. 50/60Hz
Cable:	1m Cable with CEE-16/4
Chain:	EN818-7
Dynamic safety factor for chain:	min.10:1
Grade of steel:	100
Chain surface:	galvanized
Chain Guide:	Precise chain guide with 5-pocket chain wheel
Clutch:	Patented friction clutch or overload protection
Ful load noise level(db):	≤60
Brake:	2 DC brake
Load hook:	1-fall I tumbler
Suspension:	suspension loop
Mounting position:	climbing & stationary
Plastic handles:	without
Protection level:	IP 66
Mechanism class (FEM9.511):	1Am/ 25% ED
Color:	black, RAL 9005 matt

Model	Capacity	Power (kw)	Chain Fall	Speed (m/min)	Chain (mm)	Hoist Dimension/mm							No Chain Self Weight(kg)	Chain Weight (kg/m)	Flight Case Size(mm)
						L	W	H	D	E	A	A1			
D8+ 250	250kg	0.18	1	4	4	495	325	345	105	195	26		15	0.35	81*72*45 4 in 1 28kg
D8+ 800	800kg	0.75	1	4	7.1	780	370	520	140	260	26	38	26.5	1.1	90*80*51 4 in 1 35kg

※Super small size and super light weight

※The flight case size based on Single break and Double break